

# Section DE

## DISTRIBUTION EQUIPMENT INDEX



**XEC Series**  
Circuit Breakers .....2



**B7L Series**  
Lighting Panelboards .....11-12, 14-15



**B7C Series**  
Prism Circuit Breakers .....3-6



**B7P Series**  
Power Panelboards .....11, 13, 14-15



**DEDS Series**  
Disconnect Switches  
3 Pole/Non-Fusible.....7



**D2L/D2PC Series**  
Factory Sealed Panelboards .....16-20



**XEDS/XDS Series**  
Disconnect Switches  
3 Pole/Non-Fusible.....8



**GCBB Series**  
Circuit Breaker Load Centers .....21



**EXB-NFD, EXB-FDS Series**  
Disconnect Switches  
3 Pole Non-Fusible & Fusible .....9-10



**GFCS Series**  
Ground Fault Control Station .....22

### Applications

- Hazardous areas due to the presence of flammable gases or vapors, combustible dusts, or easily ignitable fibers or flyings
- Installations at petroleum refineries, chemical and petrochemical plants, storage areas, and other processing facilities where hazardous substances are handled or stored
- Provides overcurrent and short circuit protection of service entrance, feeder or branch circuits, lighting, heating, appliance and motor circuits

### Features

- Rectangular bolted cover design provides for attractive, compact, uniform installations
- Two cast conduit hubs; one top and one bottom
- Internal circuit breaker handle mechanism is a sliding plate type mounted to the cover
- External handle is vault type with standard provisions for locking in "OFF" position with up to three padlocks
- Provisions for locking in "ON" position available as factory modification (add suffix SU40 to catalog number)
- Circuit breaker is trip free of handle mechanism
- Locking in the "ON" position does not prevent the circuit breaker from opening under short circuit or overload conditions

### Material Specifications

- Enclosure and external circuit breaker handle is cast copper-free aluminum alloy (less than 4/10 of 1%)
- Cover bolts are stainless steel



**Class I, Div. 1 & 2, Groups C,D**  
**Class I, Zones 1 & 2, Groups IIB, IIA**  
**Class II, Div. 1 & 2, Groups E,F,G**  
**Class III**  
**NEMA 7(C,D) 9(E,F,G)**



Listed - File E30962



Certified - File LR18179

See files for details or call Killark.

## FEATURES-SPECIFICATIONS

XEC CIRCUIT BREAKERS					
CATALOG NUMBER					TRIP AMPS
EHD FRAME			FDB FRAME		
1-POLE 277 VAC 125 VDC	2-POLE 240/480 VAC 250 VDC	3-POLE 240/480 VAC —	2-POLE 600 VAC 250 VDC	3-POLE 600 VAC	
XECD-154A1	XECD-154A2	XECE-154A3	XECE-156A2	XECE-156A3	15
XECD-204A1	XECD-204A2	XECE-204A3	XECE-206A2	XECE-206A3	20
XECD-304A1	XECD-304A2	XECE-304A3	XECE-306A2	XECE-306A3	30
XECD-404A1	XECD-404A2	XECE-404A3	XECE-406A2	XECE-406A3	40
XECF-504A1	XECF-504A2	XECF-504A3	XECF-506A2	XECF-506A3	50
XECF-604A1	XECF-604A2	XECF-604A3	XECF-606A2	XECF-606A3	60
XECF-704A1	XECF-704A2	XECF-704A3	XECF-706A2	XECF-706A3	70
XECF-804A1	XECF-804A2	XECF-804A3	XECF-806A2	XECF-806A3	80
XECF-904A1	XECF-904A2	XECF-904A3	XECF-906A2	XECF-906A3	90
XECF-1004A1	XECF-1004A2	XECF-1004A3	XECF-1006A2	XECF-1006A3	100
ENCLOSURE ONLY					
XECD-4A	XECD-4A	XECE-6A	XECE-6A	XECE-6A	For 40 Amp or less
XECF-6A	XECF-6A	XECF-6A	XECF-6A	XECF-6A	For 50-100 Amp

MODIFICATIONS	
SUFFIX NUMBER	DESCRIPTION
SU3	Drain and breather
SU40	Lock "ON"

NOTE: Only Cutler-Hammer Series "C" breakers fit this series. See B7C series on page DE3-6 for other brands.

ELECTRICAL RATINGS INTERRUPTING CAPACITY			
FRAME	VOLTS	AMPS SYMMETRICAL	AMPS D.C.
EHD 15-100 AMPS	240 VAC	18,000	—
	277 VAC	14,000	—
	480 VAC	14,000	—
	250 VDC	—	10,000
FDB 15-150 AMPS	240 VAC	18,000	—
	480 VAC	14,000	—
	600 VAC	14,000	—
	250 VDC	—	10,000

### Dimensions

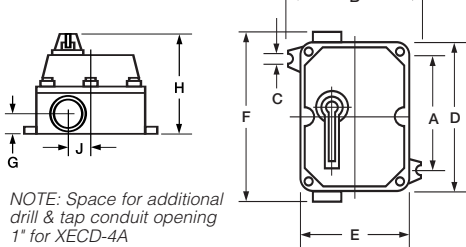

NOTE: Space for additional drill & tap conduit opening  
 1" for XECD-4A  
 1-1/4" for XECE-6A  
 2" for XECF-6A  
 Also is location for SU3 drain and breather when requested.

XEC DIMENSIONS										
CATALOG NUMBER	HUB SIZE	A	B	C	D	E	F	G	H	J
XECD-4A	1"	8-3/8" (213)	7-7/16" (189)	13/16" (21)	10-1/4" (260)	6" (152)	11-7/8" (302)	1-3/8" (35)	6-7/8" (175)	1-1/2" (38)
XECE-6A	1-1/4"	8-3/8" (213)	8-3/4" (222)	13/16" (21)	10-1/4" (260)	7-3/8" (187)	11-7/8" (302)	1-3/8" (35)	6-7/8" (175)	2" (51)
XECF-6A	2"	10-7/8" (276)	9-1/8" (232)	13/16" (21)	13-7/8" (352)	7-3/4" (197)	16" (406)	1-3/4" (44)	7" (178)	2" (51)

NOTE: A & B dimensions are for mounting.





**Class I, Div. 1 & 2, Groups B,C,D  
Class I, Zones 1 & 2, Groups IIB+H<sub>2</sub>, IIA  
Class II, Div. 1 & 2, Groups E,F,G  
Class III, Div. 1 & 2  
NEMA 3, 4, 4x, 7(B,C,D), 9(E,F,G)**

**UL** #UL1203-Explosion Proof and Dust-Ignition-Proof Electrical Equipment For Use In Hazardous (Classified) Locations. File #E83969

**SP** #C22.2 NO. 30-M1986-Explosion Proof Enclosures For Use In Class I Hazardous Locations. File #LR11714

**FEATURES-SPECIFICATIONS**



**Applications**

- Locations such as petroleum refineries, chemical and petroleum plants with indoor and outdoor processes
- Motor control and circuit protection in locations made hazardous due to the presence of flammable gases or vapors, combustible dust, or easily ignitable fibers and flyings, and areas which are subject to corrosion, weather and dampness
- To provide overcurrent and short circuit protection of service entrance, feeder or branch circuits, lighting, heating, appliance and motor circuits
- To provide line disconnect means

**Features**

- Copper-free, cast aluminum construction (less than 4/10 of 1%)
- High strength, lighter in weight, corrosion resistant
- Hinged Cover is standard
- More Wiring Room. Meets the latest NEC/CEC wire bending requirements for circuit breaker enclosures

- Ductile Mounting Lugs. Lugs are made of ductile aluminum alloy to adjust to irregular mounting surfaces without damage to enclosure
- Universal Mounting Pan. Sheet aluminum pan is pre-drilled to facilitate easy field installation of major circuit breaker brands. Provisions for grounding supplied as standard
- Conduit Openings Supplied. Standard conduit openings include power conduit top and bottom and a plugged opening suitable for field installation of drain and breather. Special conduit openings can be supplied at factory, or can be field installed
- Breaker Handle. Provisions for lock "ON" or "OFF" positions with up to three padlocks. Spring loaded to prevent damage of breaker toggle and provides positive handle alignment. "O" ring on shaft to prevent water seeping into enclosure
- Recessed Flange Notches. Flanges are notched to allow for easier cover opening with prying instrument without flange damage

- Gasketed Flange. Nitrile (BUNA-N) "O" ring gasket is located inside cover bolt circle to prevent water seeping into enclosure
- Quick Release, Captivated Cover. Bolts of 316 Grade Stainless Steel Triple lead bolts require only 3-1/2 turns to disengage

**Material/Finish**

- Enclosure: Copper-free, cast aluminum (less than 4/10 of 1%)
- Cover Bolts: 316 grade stainless steel
- Mounting Pan: Sheet aluminum
- Handle Mechanism: Cast aluminum with stainless steel shaft and hardware
- Hinges: Aluminum with stainless steel hardware
- Aluminum lacquer paint finish is standard, with special epoxy finish available. See page DE6

**FEATURES-SPECIFICATIONS**

<b>B7C CIRCUIT BREAKER ENCLOSURES</b>				
<b>ENCLOSURE ONLY CATALOG NUMBER</b>	<b>WILL ACCEPT THE FOLLOWING CIRCUIT BREAKERS:</b>			
	<b>MANUFACTURER</b>	<b>FRAME SIZE</b>	<b>CIRCUIT BREAKER TYPE</b>	<b>MAX. AMP</b>
<b>B7CA</b>	CUTLER-HAMMER/WESTINGHOUSE	F	EHD, FDB, FD, HFD, FDC	100
	GENERAL ELECTRIC	E150	TEB, TED, THED, TEL	100
	ITE - SIEMENS	ED	ED2, ED4, ED6, HED4, HED6	90
	SQUARE D	F	FAL, FHL, FCL	100
<b>B7CB</b>	CUTLER-HAMMER/WESTINGHOUSE	F	EHD, FDB, FD, HFD, FDC	150
	GENERAL ELECTRIC	E150	TEB, TED, THED, TEL	150
	ITE - SIEMENS	ED	ED2, ED4, ED6, HED4, HED6	125
<b>B7CC</b>	CUTLER-HAMMER/WESTINGHOUSE	J	JD, JDB, JDC, HJD	250
	GENERAL ELECTRIC	F225	TFJ, TFK, THFK, TFL	225
	SQUARE D	K	KAL, KHL, KCL	250
<b>B7CD</b>	CUTLER-HAMMER/WESTINGHOUSE	K	DK, KDB, KD, HKD, KDC	400
	GENERAL ELECTRIC	J600	TJJ, TJK4, THJK4	400
	ITE - SIEMENS	FD	FXD6 FD6, HFD6, CFD6	250
	ITE - SIEMENS	JD	JXD2, JXD6, JD6, HJD6, HHJD6, CJD6	400
	SQUARE D	L	LAL, LHL	400
<b>B7CE</b>	CUTLER-HAMMER/WESTINGHOUSE	L	LDB, LD, HLD, LDC	600
	GENERAL ELECTRIC	J600	TJK6, THJK6	600
	TE - SIEMENS	LD	LXD6, LD6, HLD6, HHLD6, CLD6	600
	SQUARE D	LC	LCL	600
<b>B7CF</b>	CUTLER-HAMMER/WESTINGHOUSE	N	ND, HND, NDC	1200
	GENERAL ELECTRIC	K1200	TKM8, THKM8, TKM12, THKM12	1200
	ITE - SIEMENS	MD	MD6, MXD6, HMXD6, HMD6, CMD6	800
	ITE - SIEMENS	ND	ND6, NXD6, HNXD6, CND6	1200
	SQUARE D	M	MAL, MHL	1000

NOTE: Enclosure includes mounting pan which is pre-drilled to accept circuit breakers illustrated above.

Mounting screw hardware for circuit breaker is not supplied with enclosure and must be furnished by supplier of circuit breaker.



<b>B7C ENCLOSURE WITH CIRCUIT BREAKER INSTALLED</b>							
<b>BREAKER AMPERAGE</b>	<b>MAXIMUM VOLTAGE</b>	<b>CATALOG NUMBER</b>			<b>CATALOG NUMBER</b>		
		<b>CUTLER-HAMMER/WESTINGHOUSE BREAKERS</b>			<b>SQUARE D BREAKERS</b>		
		<b>FRAME SIZE</b>	<b>2 POLE</b>	<b>3 POLE</b>	<b>FRAME SIZE</b>	<b>2 POLE</b>	<b>3 POLE</b>
15	480	EHD	B7CA-WEHD-42015	B7CA-WEHD-43015	FAL4	B7CA-SFAL-42015	B7CA-SFAL-43015
15	600	FDB	B7CA-WFDB-62015	B7CA-WFDB-63015	FAL6	B7CA-SFAL-62015	B7CA-SFAL-63015
20	480	EHD	B7CA-WEHD-42020	B7CA-WEHD-43020	FAL4	B7CA-SFAL-42020	B7CA-SFAL-43020
20	600	FDB	B7CA-WFDB-62020	B7CA-WFDB-63020	FAL6	B7CA-SFAL-62020	B7CA-SFAL-63020
30	480	EHD	B7CA-WEHD-42030	B7CA-WEHD-43030	FAL4	B7CA-SFAL-42030	B7CA-SFAL-43030
30	600	FDB	B7CA-WFDB-62030	B7CA-WFDB-63030	FAL6	B7CA-SFAL-62030	B7CA-SFAL-63030
40	480	EHD	B7CA-WEHD-42040	B7CA-WEHD-43040	FAL4	B7CA-SFAL-42040	B7CA-SFAL-43040
40	600	FDB	B7CA-WFDB-62040	B7CA-WFDB-63040	FAL6	B7CA-SFAL-62040	B7CA-SFAL-63040
50	480	EHD	B7CA-WEHD-42050	B7CA-WEHD-43050	FAL4	B7CA-SFAL-42050	B7CA-SFAL-43050
50	600	FDB	B7CA-WFDB-62050	B7CA-WFDB-63050	FAL6	B7CA-SFAL-62050	B7CA-SFAL-63050
60	480	EHD	B7CA-WEHD-42060	B7CA-WEHD-43060	FAL4	B7CA-SFAL-42060	B7CA-SFAL-43060
60	600	FDB	B7CA-WFDB-62060	B7CA-WFDB-63060	FAL6	B7CA-SFAL-62060	B7CA-SFAL-63060
70	480	EHD	B7CA-WEHD-42070	B7CA-WEHD-43070	FAL4	B7CA-SFAL-42070	B7CA-SFAL-43070
70	600	FDB	B7CA-WFDB-62070	B7CA-WFDB-63070	FAL6	B7CA-SFAL-62070	B7CA-SFAL-63070
80	480	EHD	B7CA-WEHD-42080	B7CA-WEHD-43080	FAL4	B7CA-SFAL-42080	B7CA-SFAL-43080
80	600	FDB	B7CA-WFDB-62080	B7CA-WFDB-63080	FAL6	B7CA-SFAL-62080	B7CA-SFAL-63080
90	480	EHD	B7CA-WEHD-42090	B7CA-WEHD-43090	FAL4	B7CA-SFAL-42090	B7CA-SFAL-43090
90	600	FDB	B7CA-WFDB-62090	B7CA-WFDB-63090	FAL6	B7CA-SFAL-62090	B7CA-SFAL-63090
100	480	EHD	B7CA-WEHD-42100	B7CA-WEHD-43100	FAL4	B7CA-SFAL-42100	B7CA-SFAL-43100
100	600	FDB	B7CA-WFDB-62100	B7CA-WFDB-63100	FAL6	B7CA-SFAL-62100	B7CA-SFAL-63100
125	600	FDB	B7CB-WFDB-62125	B7CB-WFDB-63125	—	—	—
125	600	JDB	B7CC-WJDB-62125	B7CC-WJDB-63125	KAL	B7CC-SKAL-62125	B7CC-SKAL-63125
150	600	FDB	B7CB-WFDB-62150	B7CB-WFDB-63150	—	—	—
150	600	JDB	B7CC-WJDB-62150	B7CC-WJDB-63150	KAL	B7CC-SKAL-62150	B7CC-SKAL-63150
175	600	JDB	B7CC-WJDB-62175	B7CC-WJDB-63175	KAL	B7CC-SKAL-62175	B7CC-SKAL-63175
200	600	JDB	B7CC-WJDB-62200	B7CC-WJDB-63200	KAL	B7CC-SKAL-62200	B7CC-SKAL-63200
225	600	JDB	B7CC-WJDB-62225	B7CC-WJDB-63225	KAL	B7CC-SKAL-62225	B7CC-SKAL-63225
250	600	JDB	B7CC-WJDB-62250	B7CC-WJDB-63250	KAL	B7CC-SKAL-62250	B7CC-SKAL-63250
250	600	KD	B7CD-WKD-62250	B7CD-WKD-63250	LAL	B7CD-SLAL-62250	B7CD-SLAL-63250
300	600	KD	B7CD-WKD-62300	B7CD-WKD-63300	LAL	B7CD-SLAL-62300	B7CD-SLAL-63300
350	600	KD	B7CD-WKD-62350	B7CD-WKD-63350	LAL	B7CD-SLAL-62350	B7CD-SLAL-63350
400	600	KD	B7CD-WKD-62400	B7CD-WKD-63400	LAL	B7CD-SLAL-62400	B7CD-SLAL-63400
400	600	LD	B7CE-WLD-62400	B7CE-WLD-63400	—	—	—
500	600	LD	B7CE-WLD-62500	B7CE-WLD-63500	LCL	B7CE-SLCL-62500	B7CE-SLCL-63500
600	600	LD	B7CE-WLD-62600	B7CE-WLD-63600	LCL	B7CE-SLCL-62600	B7CE-SLCL-63600
600	600	ND	B7CF-WND-62600	B7CF-WND-63600	MAL	B7CF-SMAL-62600	B7CF-SMAL-63600
700	600	ND	B7CF-WND-62700	B7CF-WND-63700	MAL	B7CF-SMAL-62700	B7CF-SMAL-63700
800	600	ND	B7CF-WND-62800	B7CF-WND-63800	MAL	B7CF-SMAL-62800	B7CF-SMAL-63800
1000	600	ND	B7CF-WND-621000	B7CF-WND-631000	MAL	B7CF-SMAL-621000	B7CF-SMAL-631000
1200	600	ND	B7CF-WND-621200	B7CF-WND-631200	MAL	—	—

NOTE: See page DE6 of this brochure for dimensional information and circuit breaker interrupting information.

TECHNICAL DATA INTERRUPTING CAPACITY RATINGS (SYMMETRICAL AMPERES)				
BREAKER FRAME CUTLER-HAMMER/ WESTINGHOUSE	VOLTS AC			VOLTS DC
	240	480	600	250
EHD	18,000	14,000	—	10,000
FDB	18,000	14,000	14,000	10,000
JDB	65,000	25,000	18,000	10,000
KD	65,000	35,000	25,000	10,000
LD	65,000	35,000	25,000	22,000
ND	65,000	50,000	25,000	—
<b>SQUARE D</b>				
FAL4	25,000	18,000	—	10,000
FAL6	25,000	18,000	14,000	10,000
KAL	42,000	25,000	22,000	10,000
LAL	42,000	30,000	22,000	10,000
LCL	100,000	65,000	35,000	—
MAL	42,000	30,000	22,000	14,000

Consult factory for requirements on higher interrupting rated breakers.

**Dimensions**

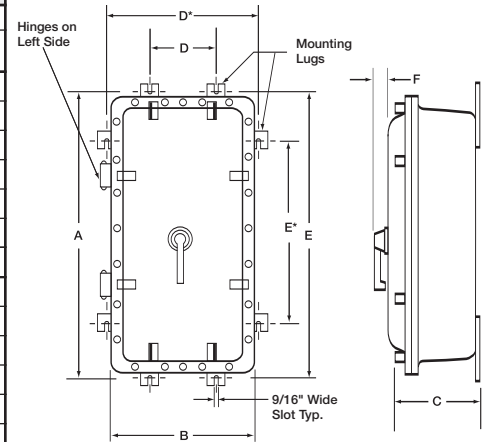

**Figure 1**

ACCESSORIES / OPTIONS*	
CATALOG NUMBER	DESCRIPTION
SU3①	Drain & breather NEMA 3, 7CD, 9EFG
SU3B①②	Drain & breather NEMA 3, 7BCD, 9EFG
B7CGRND	Grounding lug kit
B7C-SN1	Solid neutral 150 AMP
B7C-SN2	Solid neutral 250 AMP
B7C-SN3	Solid neutral 600 AMP
B7C-SN4	Solid neutral 1200 AMP
B7SF	Special epoxy finish
B7SPNPT	Change standard conduit openings

\*To be ordered as separate item with notation on order for assembly into enclosure.

NOTE: Modifications to Internal Circuit Breaker such as Shunt Trip, Auxiliary Switches, Alarm Switch and Undervoltage Release Mechanism are available and should be ordered by description.

① Installation of Drain & Breather will void the NEMA 4-4x rating.

② Not CSA

**Dimensions**

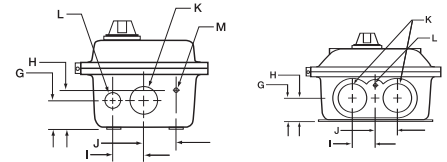

**Figure 2**

**Figure 3**

B7C DIMENSIONS													
CATALOG NUMBER	USE FIGURES	DIMENSIONS											
		A	B	C	D	D*	E	E*	F	G	H	I	J
B7CA	1, 2	18"	11"	9-1/8"	3-5/8"	N/A	16-3/8"	N/A	1-3/4"	2-15/16"	3-11/16"	2-3/8"	2-1/8"
B7CB	1, 2	26-1/4"	12-1/2"	10-3/4"	5"	N/A	24-5/8"	N/A	1-3/4"	4-5/16"	5-3/4"	2-3/4"	2-1/2"
B7CC	1, 2	34-1/4"	16-1/2"	11-1/2"	9"	N/A	32-5/8"	N/A	1-3/4"	4-11/16"	6-1/4"	4"	3-3/4"
B7CD	1, 2	34-1/4"	16-1/2"	11-1/2"	9"	N/A	32-5/8"	N/A	2-5/8"	4-11/16"	6-1/4"	4"	3-3/4"
B7CE	1, 3	45-3/8"	17-1/2"	9-5/8"	N/A	15-1/4"	N/A	33"	2-5/8"	3-3/16"	4-1/2"	2-3/4"	2-3/4"
B7CF	1, 3	62-1/4"	20-1/4"	15"	N/A	18-1/2"	N/A	43-1/2"	2-5/8"	5-3/8"	7-3/8"	3-1/2"	3-1/2"

DIMENSIONS (CONTINUED)						
CATALOG NUMBER	USE FIGURES	CONDUIT OPENINGS TOP & BTM. (NPT)			EST. ENCL. WT. (LBS.)	
		K	L	M		
B7CA	1, 2	1-1/2"	3/4"	1/2"	46	
B7CB	1, 2	2"	1"	1/2"	80	
B7CC	1, 2	3"	1"	1/2"	155	
B7CD	1, 2	3"	1"	1/2"	155	
B7CE	1, 3	3"	1/2"	N/A	215	
B7CF	1, 3	4"	1/2"	N/A	540	





**Class II, Div. 1 & 2, Groups E,F,G  
Class III  
NEMA 3R, 4, 9(E,F,G)**

Listed - File E53290

Certified - File LR11714

See files for details or call Killark.

**FEATURES-SPECIFICATIONS**

**Applications**

- Hazardous areas due to the presence of combustible dusts or easily ignitable fibers or flyings
- Use in damp or wet locations. Either indoor or outdoor installations
- Installations such as feedmills, grain elevators, coal handling facilities, certain chemical, fertilizer and food processing industries where either hazardous or non-hazardous dusts are handled or stored
- Use in accordance with the NEC/CEC where a horsepower rated quick make-quick break disconnect means for a motor and its controller is permitted

**Features**

(30-60-100 Amp Housing Styles)

- Bolted and gasketed cabinet type construction insures the exclusion of conductive or combustible dusts from entering the assembly. Enclosure and external handle is copper-free aluminum alloy (less than 4/10 of 1%)
- Cover bolts are stainless steel
- External handle is vault type with standard provisions for locking in the "OFF" position with up to three padlocks
- Provisions for locking in "ON" position available as factory modification. (Add suffix SU40 to catalog number)
- Cutler-Hammer Type-DS Switches
- Two cast conduit hubs; one top and one bottom

- Internal disconnect handle mechanism is a sliding plate mounted to the cover

DEDS DISCONNECT SWITCHES				
CATALOG NUMBER				SWITCH RATING
ENCLOSURE WITH SWITCH	ENCLOSURE WITH SWITCH AND AUXILIARY CONTACTS	ENCLOSURE WITH SWITCH AND TWO AUXILIARY CONTACTS	ENCLOSURE ONLY (WITHOUT SWITCH OR AUXILIARY CONTACTS)	
DEDS-30	DEDS-30A	DEDS-30AA	DEDS-A	30 AMP
DEDS-60	DEDS-60A	DEDS-60AA	DEDS-A	60 AMP
DEDS-100	DEDS-100A	DEDS-100AA	DEDS-B	100 AMP

Auxiliary Switch Kits are available for separate control circuit applications. Each auxiliary switch has one normally open and one normally closed contact. Each switch includes three soldered, identified leads.

Rated 15 amps at 250 volts maximum.

DEDS ELECTRICAL RATINGS					
SWITCH AMPERES	MAXIMUM HORSEPOWER—THREE PHASE—3-POLE				
	120 VAC	240 VAC	480 VAC	600 VAC	250 VDC
30	5	10	20	25	7-1/2
60	10	20	40	60	15
100	15	30	75	75	25

DEDS DIMENSIONS										
ENCLOSURE CATALOG NUMBER	CONDUIT SIZE	A	B	C	D	E	F	G	H	J
DEDS-A	1-1/4"	8-3/8" (213)	8-13/16" (224)	7/16" (11)	10-1/4" (260)	7-3/8" (187)	12-1/8" (308)	1-3/8" (35)	6-7/8" (175)	2" (51)
DEDS-B	2"	10-7/8" (276)	9-1/8" (232)	7/16" (11)	13-7/8" (252)	7-3/4" (197)	15-3/8" (391)	1-3/4" (44)	6-7/8" (175)	2" (51)

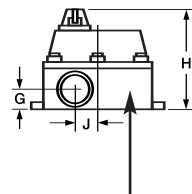
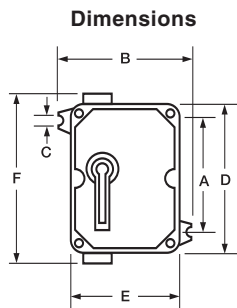

MODIFICATIONS	
SUFFIX NUMBER	DESCRIPTION
SU3 <sup>Ⓞ</sup>	Drain and breather
SU17	100 Amp solid neutral
SU40	Lock "on" for handle
KIT-251	100 Amp ground lug

<sup>Ⓞ</sup> SU3 voids NEMA 4 ratings

Note: Space for additional drill & top conduit opening. 1-1/4" for DEDS-A. 2" for DEDS-B. Also is location for SU3 drain and breather when required.



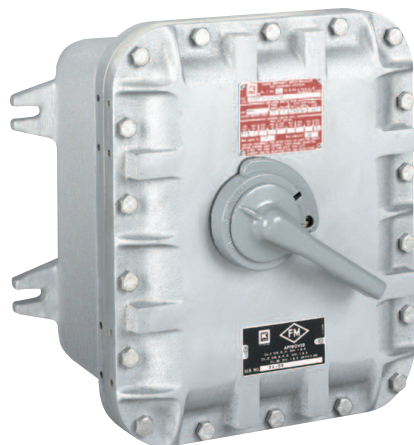

Class I, Div. 1 & 2, Groups C,D  
Class I, Zones 1 & 2, Groups IIB, IIA  
Class II, Div. 1 & 2, Groups E,F,G  
Class III  
NEMA 7(C,D) 9(E,F,G)



Files 23689 or 25217  
See files for details or call Killark.

## FEATURES-SPECIFICATIONS

### Applications

- Hazardous areas due to the presence of flammable gases or vapors, combustible dusts or easily ignitable fibers or flyings
- Installations at petroleum refineries, chemical and petrochemical plants, storage areas and other processing facilities where hazardous substances are handled or stored
- Use as motor circuit disconnect and provide short circuit protection of lighting and power circuits

### Features

- Rectangular bolted cover design provide for attractive, compact, uniform installation
- Enclosure and external handle is cast copper-free aluminum alloy (less than 4/10 of 1%)
- Cover bolts are stainless steel
- Two drilled and tapped conduit openings one top and one bottom standard on all assemblies
- Custom drilled and tapped conduit openings available on any of the four sides. (See Conduit Opening Data Chart on page E34).
- External handle is vault type with standard provisions for locking in the "OFF" position with up to three pad-locks
- Cutler-Hammer Visi-Flex Model A, Deion switches are used in all 30, 60 and 100 Ampere assemblies
- Cutler-Hammer Type DS switch is used in the 200 Ampere assembly
- Add "A" to catalog number for auxiliary contact.  
Example: 25XFS-30-30N3-A

XFS DISCONNECT SWITCHES-FUSIBLE				
CATALOG NUMBER	SWITCH RATING AMP	FUSE KIT RATING		
		AMP	VOLT	TYPE
25XFS-30-30N3	30	30	250	NEC. K or H
25XFS-60-30N3	30	60	250	NEC. K or H
25XFS-100-30N3	30	100	250	NEC. K or H
60XFS-30-30J3	30	30	600	CLASS J
60XFS-30-30N3	30	30	600	NEC. K or H
60XFS-60-30J3	30	60	600	CLASS J
60XFS-60-30N3	30	60	600	NEC. K or H
25XFS-30-60N3	60	30	250	NEC. K or H
25XFS-60-60N3	60	60	250	NEC. K or H
25XFS-100-60N3	60	100	250	NEC. K or H
60XFS-30-60J3	60	30	600	CLASS J
60XFS-30-60N3	60	30	600	NEC. K or H
60XFS-60-60J3	60	60	600	CLASS J
60XFS-60-60N3	60	60	600	NEC. K or H
25XFS-60-100N3	100	60	250	NEC. K or H
25XFS-100-100N3	100	100	250	NEC. K or H
25XFS-200-100N3	100	200	250	NEC. K or H
60XFS-60-100J3	100	60	600	CLASS J
60XFS-60-100N3	100	60	600	NEC. K or H
60XFS-100-100J3	100	100	600	CLASS J
60XFS-100-100N3	100	100	600	NEC. K or H
60XFS200-100J3	100	200	600	CLASS J
60XFS200-100N3	100	200	600	NEC. K or H
25XFSW200-200N3	200	200	250	NEC. K or H
60XFSW200-200N3	200	200	600	NEC. K or H
60XFSW200-200J3	200	200	600	CLASS J

MODIFICATIONS	
SUFFIX NUMBER	DESCRIPTION
SU2	Hinge installed (standard on 200A)
SU3	Drain and breather installed
SU40	Lock "ON"
KIT-251	100 Amp ground lug
KIT-252	225 Amp ground lug
SU17	100 Amp solid neutral





**Class I, Div. 1 & 2, Groups C,D**  
**Class I, Zones 1 & 2, Groups IIB, IIA**  
**Class II, Div. 1 & 2, Groups E,F,G**  
**Class III**  
**NEMA 7(C,D) 9(E,F,G)**

 Files 23689 or 25217  
 APPROVED See files for details or call Killark.

**FEATURES-SPECIFICATIONS**

**Dimensions**

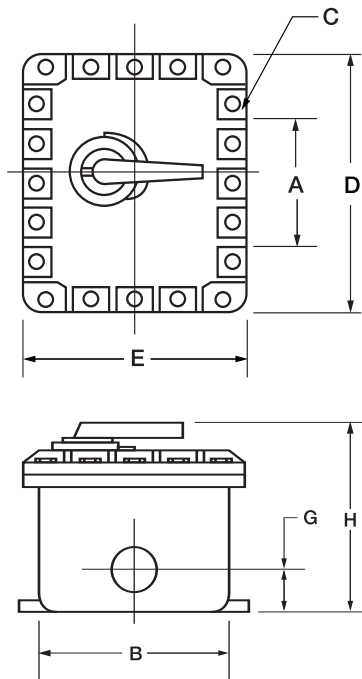

<b>XFS ELECTRICAL RATINGS</b>						
<b>SWITCH AMPERES</b>	<b>FUSE CLIP RATINGS</b>	<b>MAXIMUM HORSEPOWER-THREE PHASE-3 POLE</b>				
		<b>120 VAC</b>	<b>240 VAC</b>	<b>480 VAC</b>	<b>600 VAC</b>	<b>250 DC</b>
30	30 A./250 V.	1-1/2	3	-	-	5
30	60 A./250 V.	3	5	-	-	5
30	100 A./250 V.	-	5	-	-	-
30	30 A./600 V.	-	-	5	7-1/2	5
30	60 A./600 V.	-	-	15	20	5
60	30 A./250 V.	1-1/2	3	-	-	5
60	60 A./250 V.	3	7-1/2	-	-	10
60	100 A./250V.	-	15	-	-	10
60	30 A./600 V.	-	-	5	7-1/2	5
60	60 A./600V.	-	-	15	15	-
60	100 A./600V.	-	-	25	30	-
100	60 A./250 V.	3	7-1/2	-	-	10
100	100 A./250 V.	15	15	-	-	20
100	200 A./250 V.	15	15	-	-	20
100	60 A./600 V.	-	-	15	15	-
100	100 A./600 V.	-	-	25	30	-
100	200 A./600 V.	-	-	25	30	-
200	200 A./250 V.	-	25	50	60	40
200	200 A./600 V.	-	50	100	100	40

DE

<b>XFS DIMENSIONS</b>									
<b>SWITCH AMP RATING</b>	<b>FUSE KIT AMP RATING</b>	<b>A</b>	<b>B</b>	<b>C</b>	<b>D</b>	<b>E</b>	<b>G</b>	<b>H</b>	<b>CONDUIT SIZE</b>
30/60	30,60,100	6"(152)	10"(254)	3/8"(10)	13"(330)	11"(279)	2"(51)	9"(229)	1-1/4"
100	60,100,200	6"(152)	11-13/16"(300)	3/8"(10)	15"(381)	13"(330)	2"(51)	9"(229)	2"
200	200	19-1/2"(495)	14"(356)	1/2"(13)	27"(686)	15"(381)	3-1/8"(79)	12-3/4"(324)	3"

NOTE: A & B dimensions are for mounting.



**XEDS-30**



**XDS-2003**

**Class I, Div. 1 & 2, Groups C,D  
Class I, Zones 1 & 2, Groups IIB, IIA  
Class II, Div. 1 & 2, Groups E,F,G  
Class III  
NEMA 7(C,D) 9(E,F,G)**

Listed - File E53290

Certified - File LR1171

See files for details or call Killark.

**Applications**

- Hazardous areas due to the presence of flammable gases or vapors, combustible dusts or easily ignitable fibers or flyings
- Use in accordance with the NEC/CEC where a horsepower rated quic make-quick break disconnect means for a motor and its controller is permitted

**30-60-100-200 Amp Housing**

- External handle is vault type with standard provisions for locking in "OFF" position with up to three padlocks
- Provisions for locking in "ON" position available as factory modification (add suffix SU40 to catalog number)
- Enclosure and external handle is cast copper-free aluminum alloy (less than 4/10 of 1%)
- Cover bolts are stainless steel
- Cutler-Hammer Type-DS Switches

**30-60-100 Amp Housing**

- Two cast conduit hubs; one top and one bottom
- Internal disconnect handle mechanism is a sliding plate mounted to the cover

**200 Amp Housing**

- Two drilled and tapped conduit openings, one top and one bottom
- Custom drilled and tapped conduit openings available on any of the four sides. (See Conduit Opening Data Chart, page E34, or consult factory.)
- Drilled and tapped holes are provided with close-up plugs for field assembly of drain and breather
- Handle mechanism interlocks with disconnect switch to prevent opening of enclosure when in the "ON" position
- Aluminum hinges are supplied as standard on left side of all 200 AMP assemblies

XEDS DISCONNECT SWITCHES				
CATALOG NUMBER				SWITCH RATING
ENCLOSURE WITH SWITCH	ENCLOSURE WITH SWITCH AND AUXILIARY CONTACTS	ENCLOSURE WITH SWITCH AND TWO AUXILIARY CONTACTS	ENCLOSURE ONLY (WITHOUT SWITCH OR AUXILIARY CONTACTS)	
XEDS-30	XEDS-30A	XEDS-30AA	XEDS-A	30
XEDS-60	XEDS-60A	XEDS-60AA	XEDS-B	60
XEDS-100 <sup>①</sup>	XEDS-100A <sup>①</sup>	XEDS-100AA <sup>①</sup>	XEDS-B <sup>①</sup>	100
XDS-2003	XDS-2003A	XDS-2003AA	XDS000C	200

MODIFICATIONS	
SUFFIX NUMBER	DESCRIPTION
SU3	Drain and breather
SU17	100 Amp solid neutral
SU18	225 Amp solid neutral
SU40	Lock "on" for handle
KIT-251	100 Amp ground lug
KIT-252	225 Amp ground lug

Auxiliary switch kits are available for separate control circuit applications. Each auxiliary switch has one normally open and one normally closed contact. Each switch includes three soldered, identified leads. Rated 15 amps at 250 volts maximum.

<sup>①</sup> Due to wire gutter space, this unit must be wired with incoming (line) connection through the top hub and outgoing (load) connection to the bottom hub.

XEDS ELECTRICAL RATINGS					
SWITCH AMPERES	MAXIMUM HORSEPOWER—THREE PHASE—3-POLE				
	120 VAC	240 VAC	480 VAC	600 VAC	250 VDC
30	5	10	20	25	7-1/2
60	10	20	40	60	15
100	15	30	75	75	25
200	—	60	125	150	40

XEDS DIMENSIONS										
CATALOG NUMBER	HUB SIZE	A	B	C	D	E	F	G	H	J
XEDS-A	1-1/4"	8-3/8" (213)	8-3/4" (222)	7/16" (11)	10-1/4" (260)	7-3/8" (187)	11-7/8" (302)	1-3/8" (35)	6-7/8" (175)	2" (51)
XEDS-B	2"	10-7/8" (276)	9-1/8" (232)	7/16" (11)	13-7/8" (352)	7-3/4" (197)	16" (406)	1-3/4" (44)	7" (178)	2" (51)
XDS000C	3"	14-1/2" (368)	13-7/8" (352)	1/2" (13)	22" (559)	15" (381)	—	3-1/8" (79)	12-7/8" (327)	—

NOTE: A & B dimensions are for mounting.

**Dimensions**

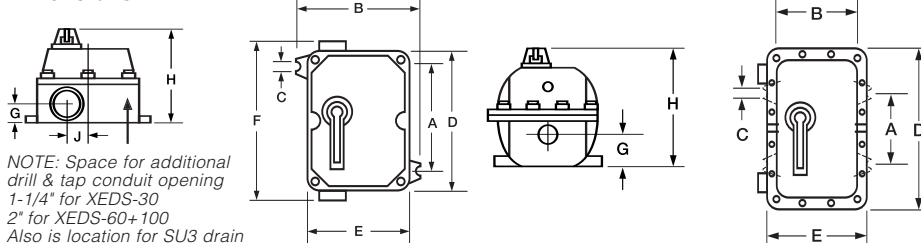

NOTE: Space for additional drill & tap conduit opening 1-1/4" for XEDS-30 2" for XEDS-60+100 Also is location for SU3 drain and breather when requested.

**XEDS**

**XDS-2003**



Class I, Div. 1 & 2, Groups B,C,D  
Class I, Zones 1 & 2, Groups IIB+ H2, IIA  
Class II, Div. 1 & 2, Groups E,F,G  
Class III  
NEMA 3, 4, 4X, 7(B,C,D) 9(E,F,G)



#UL698& #UL1203 - Explosion Proof and Dust Ignition Proof Electrical Equipment. Files #E83969 & E12379



#C22.2 No. 30-M1986 - Explosion Proof Enclosure for use in Class I Hazardous Locations. File #LR11716

**FEATURES-SPECIFICATIONS**

**Applications**

EXP-NFD and EXB-FDS Series hinged cover disconnect switches are used:

- In locations made hazardous due to the presence of flammable gasses or vapors or ignitable dusts, fibers and flyings.
- Outdoors or indoors in damp, wet and dirty locations, or in areas where frequent washdowns, heavy rain or water spray routinely occurs.
- Use as motor circuit disconnect and to provide short circuit protection (fused version) of lighting and power circuits.

**Features**

- Copper-free aluminum construction, high strength, lighter in weight and corrosion resistant.
- Fewer cover bolts (no corner bolts required) reduces installation and maintenance time. Cover bolts are stainless steel.
- Gasketed flange with O-ring located in side bolt circle to seal out moisture.
- Stainless steel hinges are standard.
- Switch operating handle of copper-free aluminum can be padlocked, with up to 3 locks, in either the "ON" or "OFF" position.
- Ductile mounting lugs adjust to irregular mounting surfaces.
- Bodies have top and bottom drilled and tapped conduit entrances for power and drain/breather.
- **ABB** Switches are used on all 30 to 400 Ampere assemblies.
- For Horsepower Ratings and Dimensions, see page DE10.
- Disconnect Switches suitable for type 'J' fuses only.

**EXB-NFD NON FUSED DISCONNECT SWITCHES**

CATALOG NUMBER	SWITCH RATING	TYPE	CONDUITS top/bot.	WIRE SIZE
<b>EXB-NFD-0303P</b>	30	3 Pole	(1) 2" (1) 1/2"	#14-4
<b>EXB-NFD-0306P</b>	30	6 Pole	(2) 2" (1) 1/2"	#14-4
<b>EXB-NFD-0303PDT</b>	30	3P Double Throw	(2) 2" (1) 1/2"	#14-4
<b>EXB-NFD-0603P</b>	60	3 Pole	(1) 2" (1) 1/2"	#14-4
<b>EXB-NFD-0606P</b>	60	6 Pole	(2) 2" (1) 1/2"	#14-4
<b>EXB-NFD-0603PDT</b>	60	3P Double Throw	(2) 2" (1) 1/2"	#14-4
<b>EXB-NFD-1003P</b>	100	3 Pole	(1) 2" (1) 1/2"	#8- 1/0
<b>EXB-NFD-1006P</b>	100	6 Pole	(2) 2" (1) 1/2"	#8-1/0
<b>EXB-NFD-1003PDT</b>	100	3P Double Throw	(2) 2" (1) 1/2"	#8-1/0
<b>EXB-NFD-2003P</b>	200	3 Pole	(1) 3" (1) 1/2"	#4-300MCM
<b>EXB-NFD-4003P</b>	400	3 Pole	(2) 3" (1) 1/2"	#2-600MCM

**EXB-FDS FUSED DISCONNECT SWITCHES (Type J Fuses)**

CATALOG NUMBER	SWITCH RATING	TYPE	CONDUITS top/bot.	WIRE SIZE
<b>EXB-FDS-0303P</b>	30	3 Pole	(1) 2" (1) 1/2"	#14-4
<b>EXB-FDS-0603P</b>	60	3 Pole	(1) 2" (1) 1/2"	#14-4
<b>EXB-FDS-1003P</b>	100	3 Pole	(1) 2" (1) 1/2"	#14-2/0
<b>EXB-FDS-2003P</b>	200	3 Pole	(1) 3" (1) 1/2"	#4-300MCM
<b>EXB-FDS-4003P</b>	400	3 Pole	(2) 3" (1) 1/2"	#2-600MCM

**Standard Materials/Finish**

- Enclosures: Copper-free aluminum (less than 4/10 of 1% copper content)
- Hinges and Cover Bolts: Stainless steel
- Aluminum lacquer paint finish

**Electrical Rating Ranges**

- 600 VAC
- 30, 60, 100, 200 and 400 Amp

Consult Factory for special conduit layouts and ATEX requirements

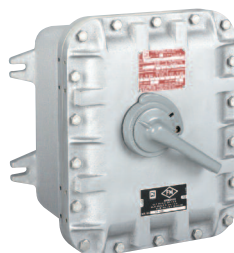

**MODIFICATIONS**

SUFFIX NUMBER	DESCRIPTION
<b>KIT-251</b>	100 amp ground lug
<b>KIT-252</b>	225 amp ground lug
<b>SU3*</b>	Drain/Breather install NEMA 7CD
<b>SU3B*</b>	Drain/Breather install NEMA 7BCD
<b>SU9</b>	Special Paint Finish
<b>4P</b>	4th pole 30, 60, 100A - 3 pole only*
<b>A</b>	1 NC+1NO Auxiliary
<b>AA</b>	2 NC+2NO Auxiliary

*NOTE: The installation of a Drain & Breather will void the NEMA 4-4X ratings of enclosure.  
\*non-fused*

For this product housed in an XB style enclosure (Series XFS) See DE8A and DE9B in PDF Catalog at [www.hubbell-killark.com](http://www.hubbell-killark.com)



Class I, Div. 1 & 2, Groups B,C,D  
Class I, Zones 1 & 2, Groups IIB+ H2, IIA  
Class II, Div. 1 & 2, Groups E,F,G  
Class III  
NEMA 3, 4, 4X, 7(B,C,D) 9(E,F,G)



#UL698 & #UL1203 - Explosion Proof and Dust Ignition Proof Electrical Equipment. Files #E83969 & E12379



#C22.2 No. 30-M1986 - Explosion Proof Enclosure for use in Class I Hazardous Locations. File #LR11716

### FEATURES-SPECIFICATIONS

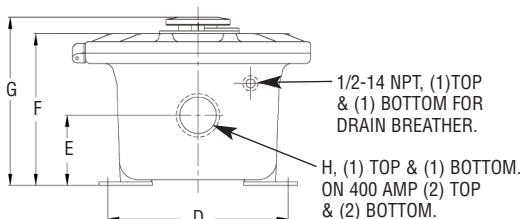
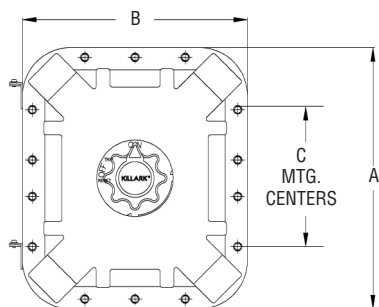

#### EXB-NFD ELECTRICAL RATINGS

SWITCH AMPERES	MAXIMUM HORSEPOWER - THREE PHASE-3 POLE				
	200-208 VAC	240 VAC	480 VAC	600 VAC	230 VDC
30	10	10	20	30	1
60	20	20	40	40	10
100	25	30	50	50	20
200	60	75	150	200	75
400	100	125	250	350	150

#### EXB-FDS ELECTRICAL RATINGS

SWITCH AMPERES	MAXIMUM HORSEPOWER - THREE PHASE-3 POLE				
	200-208 VAC	240 VAC	480 VAC	600 VAC	230 VDC
30	5.7.5	7.5	15	20	7.5
60	15	15	30	50	20
100	25	30	50	60	50
200	50	60	125	150	60
400	100/125	125	250	350	150

#### EXB-NFD DIMENSIONS

AMP RATING	A	B	C	D	E	F	G	CONDUIT SIZE H
30/60	12-5/16	12-5/16	6	9-7/8	3-13/16	8-1/8	9-7/17	2"
100	14-5/16	12-5/16	8	9-7/8	3-7/8	8-5/16	9-5/8	2"
200	28-3/8	16-3/8	18-7/8	14-15/16	5-3/8	11-5/16	12-5/8	3"
400	41-1/4	17-1/4	31	15	5-3/16	11-3/8	12-11/16	(2) 3"



#### EXB-NFD DIMENSIONS

AMP RATING	A	B	C	D	E	F	G	CONDUIT SIZE H
30	14-5/16	12-5/16	8	9-7/8	3-7/8	8-15/16	9-5/8	2"
60	15-1/4	15-1/4	14-15/16	12-15/16	5-1/16	10-15/16	12-1/4	2"
200	22-3/8	16-3/8	12-7/8	14-15/16	5-3/8	11-1/16	12-3/8	2"
200	28-3/8	16-3/8	18-7/8	14-15/16	5-3/8	11-15/16	13-3/8	3"
400	40-3/8	22-3/8	31-1/2	21-1/4	14-3/8	14-3/8	16-1/2	(2) 3"





**Class I, Div. 1 & 2, Groups B,C,D**  
**Class I, Zones 1 & 2, Groups IIB+H<sub>2</sub>, IIA**  
**Class II, Div. 1 & 2, Groups E,F,G**  
**Class III, Div. 1 & 2**  
**NEMA 3, 4, 4x, 7(B,C,D) 9(E,F,G)**

  Classified — File E83969  
 See files for details or call Killark.  
 Certified-File LR 11713 for B7L

**FEATURES-SPECIFICATIONS**



**Applications**

- Hazardous locations due to the presence of flammable gases or vapors, combustible dust or easily ignitable fibers and flyings, and areas subject to corrosion, weather and dampness
- Petroleum refineries, chemical and petrochemical plants with indoor and outdoor processes
- Applications requiring overcurrent and short circuit protection of lighting, appliances, heating and motor circuits

**Features**

- NEMA 4, 4x rated for protection from hose directed water and corrosion
- Standard electrical components: B7L-Cutler-Hammer Quicklag Breakers B7P-Cutler-Hammer Series C Breakers
- B7L and B7P furnished with copper buss
- Main lugs. Mechanical solderless type, approved for CU or AL conductors
- Solid Neutral standard. Single phase 3 wire. Three phase 4 wire
- Copper ground bar standard
- Main and branch breaker handles can be padlocked in “ON” or “OFF” position
- Top feed panel standard with bottom feed optional
- Hinged cover, installed as standard
- Quick release, captivated coverbolts of 316 stainless steel

**Standard Materials**

- Enclosure: Copper-free aluminum (less than 4/10 of 1%)
- Main Breaker Handle: Copper-free aluminum
- Cover bolts: 316 grade stainless steel
- Flange Gasket “O” Ring: Buna-N Nitrile
- Branch Breaker Operators: Valox Thermoplastic Polyester handle molded onto 316 stainless steel shaft with neoprene “O” ring
- Hinges: Copper-free aluminum with stainless steel pin and hardware
- Mounting Lugs: 1/4” thick aluminum

**Panel Selection Factors**

Basic information required when specifying panelboards is as follows:

- Environment
- Service (Voltage/Frequency/Phase)
- Interrupting capacity
- AMP Rating of Main (Lugs only or Breaker)
- Branch Breaker (Type/Number of Poles/Amperage)

**Ordering Information**

Specifying and ordering a complete panelboard assembly requires the selection of three components.

**(1) Basic Panel (2) Branch Breaker and (3) Options** (if required). This method of cataloging permits a wide variety and maximizes circuit flexibility in our panelboard offering. Components supplied in each of these selections include:

- 1) Basic Panelboard Enclosures (page DE12)**
  - Explosion-proof enclosure consisting of box and cover
  - Cover predrilled and plugged for maximum number of branch breaker handles (handles not supplied)

- Box supplied with conduit openings
  - Main circuit breaker and external handle (when specified)
  - Panelboard internal chassis with buss bars but less branch circuit breakers
- 2) Branch Circuit Breakers (page DE14)**
- Internal circuit breaker
  - External handle mechanism with internal tripping mechanism
  - Test pushbutton for GFI (when ordered)
  - Lockout shield with on-off-trip-reset identification

**3) Options - Accessories (page DE14)**

**Ordering Example**

Specification is for a 3 phase 120/208 volt panel with 100 Amp main lugs complete with (4) single pole 20 Amp (2) double pole 20 Amp and (1) three pole 30 Amp branch breakers.

Branch Breaker Total =  
 (4) 1 Pole = 4 Poles Total  
 (2) 2 Pole = 4 Poles Total  
 (1) 3 Pole = 3 Poles Total  
        Total 11 Branch Poles        

Specification/Ordering Example  
 B7L20 - 312 - ML100 (Basic panelboard enclosure) with:

- (4) B7BLA1020 (1 Pole 20 Amp Branch)
- (2) B7BLA2020 (2 Pole 20 Amp Branch)
- (1) B7BLB3030 (3 Pole 30 Amp Branch)

**Catalog Logic**

See page DE15 for panelboard catalog number logic for basic enclosures.

**Cutler-Hammer type BA circuit breaker 1 - 2 or 3 pole.**

Catalog numbers on this page are for the basic panelboard enclosure only with a panel interior chassis containing main lugs or main breaker as illustrated. **Internal branch breakers and external handles are NOT included in the basic enclosure catalog number and must be ordered as separate items.**

**Branch circuit loads**

The interior panel chassis supplied in B7L panel is limited to a maximum of 140 amperes at any one connection point. Breakers of 50 thru 100 amps must be installed opposite breakers of smaller amperage so as not to exceed the 140 ampere limitation.

CIRCUIT BREAKER RATINGS			
TYPE	NO. OF POLES	VOLT	AMPERES SYMMETRICAL
BAB*	1	120	10,000 AIC
BAB*	2	120/240	10,000 AIC
BAB*	3	240	10,000 AIC
BABSWN*	1	120/240	10,000 AIC
BABSWN*	2	120/240	10,000 AIC
QGBF	1	120	10,000 AIC
QGBF	2	120/240	10,000 AIC
QGBFEP	1	120	10,000 AIC
QGBFEP	2	120/240	10,000 AIC

\*Type BAB also rated for 80V DC at 5,000 AIC.

**Class I, Div. 1 & 2, Groups B,C,D  
Class I, Zones 1 & 2, Groups IIB+H<sub>2</sub>, IIA  
Class II, Div. 1 & 2, Groups E,F,G  
Class III, Div. 1 & 2  
NEMA 3, 4, 4x, 7(B,C,D) 9(E,F,G)**



Classified — File E83969

See files for details or call Killark.



Certified-File LR 11713

B7L PANEL WITHOUT MAIN BREAKER (MAIN LUGS ONLY) LESS BRANCH BREAKERS					
ELECTRICAL RATING	MAIN LUG RATING	NUMBER OF BRANCH POLES	CATALOG NUMBER BASIC ENCLOSURE AND CHASSIS	ENCLOSURE BOX SIZE	MAIN WIRE RANGE
Single phase 3 wire with solid neutral 120/240 VAC	100	12	B7L20 - 112 - ML100	A	E
	100	18	B7L29 - 118 - ML100	B	G
	225	18	B7L29 - 118 - ML225	B	F
	100	24	B7L29 - 124 - ML100	B	G
	225	24	B7L41 - 124 - ML225	C	F
	100	30	B7L41 - 130 - ML100	C	G
	225	30	B7L41 - 130 - ML225	C	F
	225	36	B7L41 - 136 - ML225	C	F
Three phase 4 wire with solid neutral 120/208 VAC	100	12	B7L20 - 312 - ML100	A	E
	100	18	B7L29 - 318 - ML100	B	G
	225	18	B7L29 - 318 - ML225	B	F
	100	24	B7L29 - 324 - ML100	B	G
	225	24	B7L41 - 324 - ML225	C	F
	100	30	B7L41 - 330 - ML100	C	G
	225	30	B7L41 - 330 - ML225	C	F
	225	36	B7L41 - 336 - ML225	C	F
	225	42	B7L41 - 342 - ML225	C	F

B7L PANEL WITH MAIN BREAKER LESS BRANCH BREAKERS						
ELECTRICAL RATING	MAIN BREAKER FRAME	MAIN BREAKER AND RATING	NUMBER OF BRANCH POLES	CATALOG NUMBER BASIC ENCLOSURE AND CHASSIS	ENCLOSURE BOX SIZE	MAIN WIRE RANGE
Single phase 3 wire with solid neutral 120/240 VAC	EHD	100	12	B7L29 - 112 - MBE100	B	H
	EHD	100	18	B7L41 - 118 - MBE100	C	H
	EHD	100	24	B7L41 - 124 - MBE100	C	H
	ED	225	24	B7L41 - 124 - MBC225	C	I
	EHD	100	30	B7L41 - 130 - MBE100	C	H
	ED	225	30	B7L41 - 130 - MBC225	C	I
	ED	225	36	B7L50 - 136 - MBC225	D	I
Three phase 4 wire with solid neutral 120/208 VAC	ED	225	42	B7L50 - 142 - MBC225	D	I
	EHD	100	12	B7L29 - 312 - MBE100	B	H
	EHD	100	18	B7L41 - 318 - MBE100	C	H
	EHD	100	24	B7L41 - 324 - MBE100	C	H
	ED	225	24	B7L41 - 324 - MBC225	C	I
	EHD	100	30	B7L41 - 330 - MBE100	C	H
	ED	225	30	B7L41 - 330 - MBC225	C	I
ED	225	36	B7L50 - 336 - MBC225	D	I	
	ED	225	42	B7L50 - 342 - MBC225	D	I

B7L PANEL WITH BACK FEED MAIN BREAKER LESS BRANCH BREAKERS						
ELECTRICAL RATING	MAIN BREAKER FRAME	MAIN BREAKER AND RATING	NUMBER OF BRANCH POLES	CATALOG NUMBER BASIC ENCLOSURE AND CHASSIS	ENCLOSURE BOX SIZE	MAIN WIRE RANGE
Single phase 3 wire with solid neutral 120/240 VAC	BAB	100	12	B7L29 - 112 - MBB100	B	J
	BAB	100	18	B7L29 - 118 - MBB100	B	J
	BAB	100	24	B7L41 - 124 - MBB100	C	J
	BAB	100	30	B7L41 - 130 - MBB100	C	J
Three phase 4 wire with solid neutral 120/208 VAC	BAB	100	12	B7L29 - 312 - MBB100	B	J
	BAB	100	18	B7L29 - 318 - MBB100	B	J
	BAB	100	24	B7L41 - 324 - MBB100	C	J
	BAB	100	30	B7L41 - 330 - MBB100	C	J

NOTE: Main breaker panel includes main breaker and its price in basic enclosure part number. Refer to page DE14 for branch breaker ordering information.



**Cutler-Hammer Series “C” Circuit Breakers 1-2 or 3 pole.**

Catalog numbers on this page are for the basic panelboard enclosure only with a panel interior chassis containing main lugs or main breaker as illustrated. Internal branch breakers and external handles are NOT included in the basic enclosure catalog number and must be ordered as separate items.

**Class I, Div. 1 & 2, Groups B,C,D  
Class I, Zones 1 & 2, Groups IIB+H<sub>2</sub>, IIA  
Class II, Div. 1 & 2, Groups E,F,G  
Class III, Div. 1 & 2  
NEMA 3, 4, 4x, 7(B,C,D) 9(E,F,G)**

  Classified — File E83969  
See files for details or call Killark.

**FEATURES-SPECIFICATIONS**

B7P CIRCUIT BREAKER RATINGS									
TYPE	NUMBER OF POLES	MAXIMUM VOLTS		AMPERES SYMMETRICAL					
		AC	DC	240AC	277AC	480AC	600AC	125DC	250DC
EHD	1	277	125	—	14000	—	—	10000	—
EHD	2&3	480	250	18000	—	14000	—	—	10000
FDB	2&3	600	250	18000	—	14000	14000	—	10000

B7P PANEL WITHOUT MAIN BREAKER (MAIN LUGS ONLY) LESS BRANCH BREAKERS					
ELECTRICAL RATING	MAIN LUG RATING	NUMBER OF BRANCH POLES	CATALOG NUMBER ENCLOSURE AND CHASSIS	ENCLOSURE BOX SIZE	MAIN WIRE RANGE
3 Phase 4 Wire with solid neutral up to 600 VAC	100	6	B7P20 - 306 - ML100	A	K
	100	12	B7P29 - 312 - ML100	B	K
	225	12	B7P29 - 312 - ML225	B	L
	225	18	B7P41 - 318 - ML225	C	L
	100	21	B7P41 - 321 - ML100	C	K
	225	27	B7P50 - 327 - ML225	D	M

B7P PANEL WITH MAIN BREAKER LESS BRANCH BREAKERS							
ELECTRICAL RATING	MAIN BREAKER			NUMBER OF BRANCH POLES	CATALOG NUMBER ENCLOSURE AND CHASSIS	ENCLOSURE BOX SIZE	MAIN WIRE RANGE
	MAX. VOLTS	AMPS	FRAME				
3 Phase 4 Wire with Solid Neutral Up to 600 VAC	480	100	EHD	6	B7P29 - 306 - MBE100	B	K
	600	100	FDB	6	B7P29 - 306 - MBF100	B	K
	600	225	JDB	12	B7P41 - 312 - MBJ225	C	L
	480	100	EHD	15	B7P41 - 315 - MBE100	C	K
	600	100	FDB	15	B7P41 - 315 - MBF100	C	K
	600	225	JDB	18	B7P50 - 318 - MBJ225	D	L
	480	100	EHD	21	B7P50 - 321 - MBE100	D	N
	600	100	FDB	21	B7P50 - 321 - MBF100	D	N

PANEL WITH BACK FEED MAIN BREAKER LESS BRANCH BREAKERS							
ELECTRICAL RATING	MAIN BREAKER			NUMBER OF BRANCH POLES	CATALOG NUMBER ENCLOSURE AND CHASSIS	ENCLOSURE BOX SIZE	MAIN WIRE RANGE
	MAX. VOLTS	AMPS	FRAME				
3 Phase 4 Wire with solid neutral up to 600 VAC	480	100	EHD	9	B7P29 - 309 - MBE100	B	K
	600	100	FDB	9	B7P29 - 309 - MBF100	B	K
	480	100	EHD	18	B7P41 - 318 - MBE100	C	K
	600	100	FDB	18	B7P41 - 318 - MBF100	C	K
	480	100	EHD	24	B7P50 - 324 - MBE100	D	K
	600	100	FDB	24	B7P50 - 324 - MBF100	D	K

NOTE: Main breaker panel includes main breaker and its price in basic enclosure part number. Refer to page DE14 for branch breaker ordering information. See page DE15 for enclosure dimensions.

BRANCH CIRCUIT BREAKERS							
NUMBER OF POLES PER BREAKER	TRIP AMP RATING	B7L SERIES LIGHTING PANEL				B7P SERIES POWER PANEL	
		BAB FRAME STANDARD	BAB FRAME SWITCH NEUTRAL	QBGF GROUND FAULT 5MA	QBGEQ EQUIPMENT PROTECTION 30MA	EHD FRAME 480 VAC MAX.	FDB FRAME 600 VAC MAX.
(1) Single Pole 120 Volt	SPACE	B7BLA1000	—	B7BLC1000	B7BLE1000	B7BPK1000	—
	15	B7BLA1015	—	B7BLC1015	B7BLE1015	B7BPK1015	—
	20	B7BLA1020	—	B7BLC1020	B7BLE1020	B7BPK1020	—
	30	B7BLA1030	—	B7BLC1030	B7BLE1030	B7BPK1030	—
	40	B7BLA1040	—	—	—	B7BPK1040	—
	50	B7BLA1050	—	—	—	B7BPK1050	—
	60	B7BLA1060	—	—	—	B7BPK1060	—
	70	B7BLA1070	—	—	—	B7BPK1070	—
	90	—	—	—	—	B7BPK1090	—
	100	B7BLA1100	—	—	—	B7BPK1100	—
(2) Double Pole 120/240 Volt	SPACE	B7BLA2000	B7BLF2000	B7BLC2000	B7BLE2000	B7BPK2000	B7BPL2000
	15	B7BLA2015	B7BLF2015	B7BLC2015	B7BLE2015	B7BPK2015	B7BPL2015
	20	B7BLA2020	B7BLF2020	B7BLC2020	B7BLE2020	B7BPK2020	B7BPL2020
	30	B7BLA2030	B7BLF2030	B7BLC2030	B7BLE2030	B7BPK2030	B7BPL2030
	40	B7BLA2040	—	B7BLC2040	B7BLE2040	B7BPK2040	B7BPL2040
	50	B7BLA2050	—	—	—	B7BPK2050	B7BPL2050
	60	B7BLA2060	—	—	—	B7BPK2060	B7BPL2060
	70	B7BLA2070	—	—	—	B7BPK2070	B7BPL2070
	90	B7BLA2090	—	—	—	B7BPK2090	B7BPL2090
	100	B7BLA2100	—	—	—	B7BPK2100	B7BPL2100
(3) Three Pole 120/240 Volt	SPACE	B7BLB3000	B7BLF3000	—	—	B7BPK3000	B7BPL3000
	15	B7BLB3015	B7BLF3015	—	—	B7BPK3015	B7BPL3015
	20	B7BLB3020	B7BLF3020	—	—	B7BPK3020	B7BPL3020
	30	B7BLB3030	B7BLF3030	—	—	B7BPK3030	B7BPL3030
	40	B7BLB3040	—	—	—	B7BPK3040	B7BPL3040
	50	B7BLB3050	—	—	—	B7BPK3050	B7BPL3050
	60	B7BLB3060	—	—	—	B7BPK3060	B7BPL3060
	70	B7BLB3070	—	—	—	B7BPK3070	B7BPL3070
	90	B7BLB3090	—	—	—	B7BPK3090	B7BPL3090
	100	B7BLB3100	—	—	—	B7BPK3100	B7BPL3100
	110	—	—	—	—	—	B7BPL3110
	125	—	—	—	—	—	B7BPL3125
150	—	—	—	—	—	B7BPL3150	

MODIFICATIONS	
CATALOG NUMBER	DESCRIPTION
SU3	Drain and breatherⓄNEMA 3, 7CD, 9 EFG
SU3B	Drain and breatherⓄNEMA 3, 7BCD, 9EFG
KIT-251	Grounding kit, 100 AMP
KIT-252	Grounding kit, 225 AMP
B7SF	Special baked epoxy finish
B7EYEBOLT	Eye bolts for ease of installationⓄ
B7ML225	Change 100 amp buss to 225 amp B7P series
B7ML400	Change 225 amp buss to 400 amp B7P series
B7MLBTM	Main lugs at bottom
B7SPNPT	Change standard conduit size and location
B7GSN	Kit to ground neutral bar

### Branch Breaker Notes:

- 1) B7L panels are factory drilled for maximum number of single pole branch breaker handles and B7P for maximum number of 3 pole branch breaker handles as standard.
- 2) Part numbers illustrated above include external handle, trip mechanism, locking tab and internal breaker. Refer to page DE11 for complete ordering information and examples.
- 3) Space = External handle, shaft and trip mechanism installed to allow for future installation of breaker.
- 4) Ground Fault & Equipment protection breakers include external pushbutton for each breaker to test ground fault sensing circuit and the mechanical operation of breaker.
- 5) Switch Neutral Breaker note. A two pole breaker has one pole for breaking from main buss and one pole that breaks neutral. Three pole breaker consists of two poles for breaking from main buss and one pole that breaks neutral.

\* To be ordered as separate item with notation on order for assembly into enclosure.

- Ⓞ Installation of drain and breather will void the NEMA 4-4X Rating of panelboard.  
Drain and breather will be installed into a standard conduit opening provided in box.
- Ⓞ Lifting eyebolts are installed in two conduit openings located in top of box and are to be removed after installation.



# KILLARK®



**Catalog Logic- for basic Panelboard Enclosures**

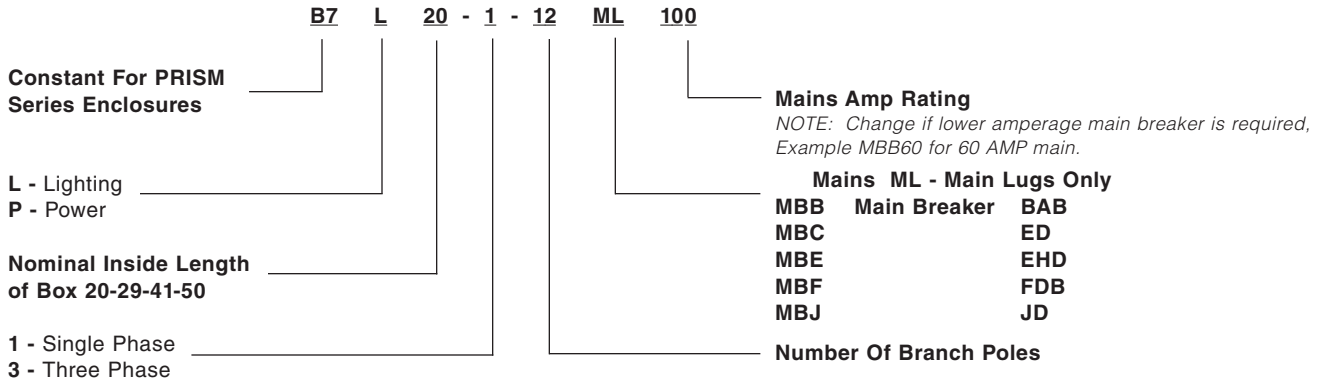

WIRE SIZES									
E	F	G	H	I	J	K	L	M	N
#12-#1	#6-250MCM	#12-1/0	#14-1/0	2/0-250MCM	#14-#1	#6-2/0	#6-4/0	#2-4/0	#2-2/0

**Wiring Diagrams B7L Series**

(Note: B7P Series are single column)

**Main Lug Only**  
**Three Phase 4-Wire**  
**Solid Neutral**  
**120/208 VAC**

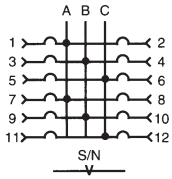

**Main Lug Only**  
**Single Phase 3-Wire**  
**Solid Neutral**  
**120/240 VAC**

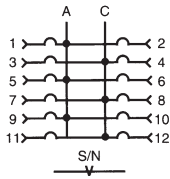

**Back Feed**  
**Main Breaker**  
**Three Phase 4-Wire**  
**Solid Neutral**  
**120/208 VAC**

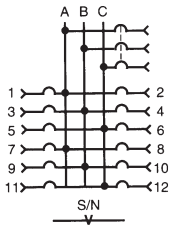

**Back Feed**  
**Main Breaker**  
**Single Phase 3-Wire**  
**Solid Neutral**  
**120/240 VAC**

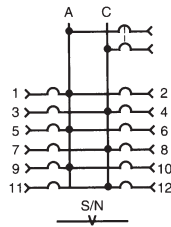

**Vertical**  
**Main Breaker**  
**Three Phase 4-Wire**  
**Solid Neutral**  
**120/208 VAC**

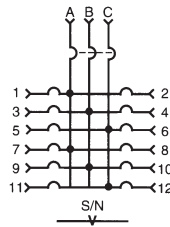

**Vertical**  
**Main Breaker**  
**Single Phase 3-Wire**  
**Solid Neutral**  
**120/240 VAC**

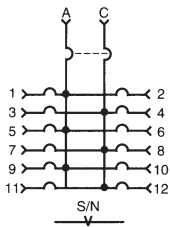

DIMENSIONS										
ENCLOSURE BOX SIZE		X	Y	CONDUIT SIZE		Z	CONDUIT QUANTITY			
LETTER	BASE BOX NUMBER ①			A	B, C, D		A	B	C	D
A	MXB-13207	24-3/4" (629)	13" (330)	2"	1"	6-7/8" (175)	2	3	3	4
B	MXB-13297	33-3/8" (848)	21" (533)	2-1/2"	1"	10-7/8" (276)	2	3	4	5
C	MXB-13417	45-3/8" (1153)	33" (838)	3"	1"	16-7/8" (429)	2	3	5	6
D	MXB-13507	54-3/8" (1381)	42" (1067)	3"	1"	21-3/8" (543)	2	3	6	7

① See pages DE12 and DE13 for complete enclosure ordering information.

**Dimensions**

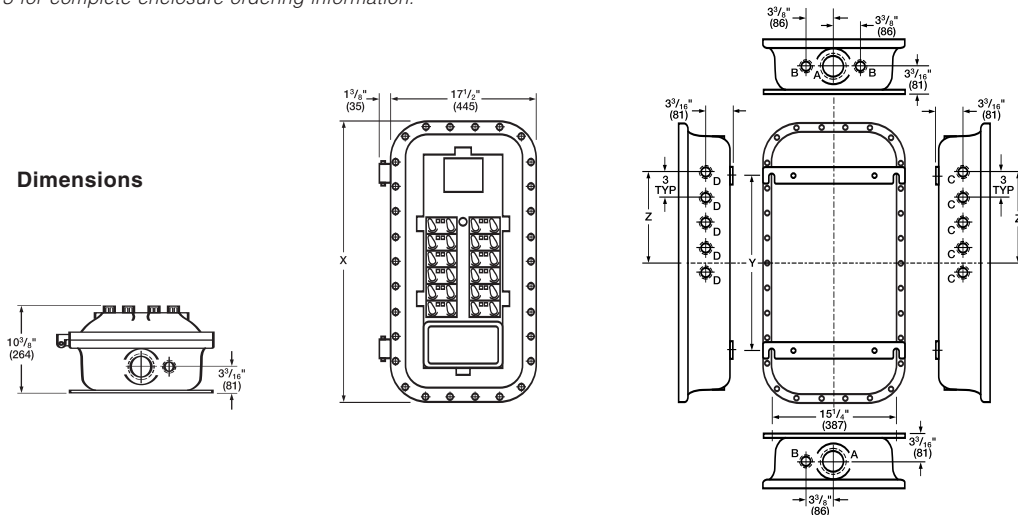



**Class I, Div. 2, Groups B,C,D**  
**Class I, Zone 2, Groups IIB+H<sub>2</sub>, IIA**  
**Class II, Div. 2, Groups F,G**  
**Class III, Div. 1 & 2**  
**NEMA, CSA Type 3, 4 (4X Optional)**



Classified — File E83969



Certified — File LR11713

## FEATURES-SPECIFICATIONS

### Applications

- Hazardous areas due to the potential of explosive gas atmospheres, combustible dusts or easily ignited fibers or flyings and areas subjected to corrosive or harsh chemicals, weather or dampness
- Petroleum refineries, chemical or petrochemical facilities with indoor or outdoor processes
- Applications requiring overcurrent and short circuit protection of lighting, appliances heating or motor circuits

### Features

- Factory Seal between breaker enclosure and termination box eliminates the need for external sealing
- Gasketed covers assure NEMA/CSA Type 4, 4X rated protection for hose-down and corrosion
- Standard Electrical Components: D2L–Cutler-Hammer QC Breakers D2CP–Cutler-Hammer GHC & GCH Breakers
- Main distribution block, branch terminal block, neutral and ground bar are located in termination enclosure
- Main Lugs. Mechanical solderless type, approved for CU or AL conductors
- Solid neutral standard. Single phase, 3 wire or three phase 4 wire
- Main and branch circuit breaker handles can be padlocked in “on” or “off” position

- Top or bottom feed panels available
- Breaker chamber hinged cover with quick release – captivated bolts
- Termination enclosure has hinged cover with quick release latch for easy opening
- Termination enclosure supplied without conduit openings for easy field punching of incoming and outgoing entries
- Line and load side of breakers in breaker chamber are factory wired to terminal blocks in termination enclosure and sealed at the factory
- Breaker enclosure is drilled and plugged for maximum number of circuits to permit field addition of unused branch spaces

### Panel Selection Factors

- Basic information required when specifying panelboards is as follows:
  - Service Requirements – Voltage, phases and frequency
  - Interrupting capacity
  - Amperage Rating of Main (Lugs only or Breaker)
- Branch Breaker Requirements
  - Type
  - Number
  - Poles
  - Amperage
  - GFCI Requirements

### Ordering Information

Specifying and ordering a complete panelboard assembly requires the selection of three components

1. Basic Panel
2. Branch Breakers
3. Modifications if Required

This method of cataloguing permits a wide variety and maximizes circuit flexibility in the Killark panelboard series.

### Standard Materials

- Breaker Enclosure: Copper-free cast aluminum (less than 4/10 of 1%)
- Terminal enclosure: Steel powder coated. (Optional stainless steel or fiberglass for 4X ratings)
- Cover bolts: Type 316 stainless steel

MODIFICATIONS	
SUFFIX NUMBER	DESCRIPTION
SU3	Drain and breather C&D <sup>①</sup>
SU3B	Drain and breather B,C,D <sup>①②</sup>
D2SF	Powder paint on breaker box
D2MLBTM	Invert with terminal box located on bottom
D2STST	Substitute with stainless steel termination box
D2FG	Substitute with fiberglass termination box
B7GSN	Kit to ground neutral bar
D2CA	Substitute with cast aluminum termination box

<sup>①</sup>Installation of drain breather will void the NEMA 4-4x rating of panelboard.

<sup>②</sup>Not CSA



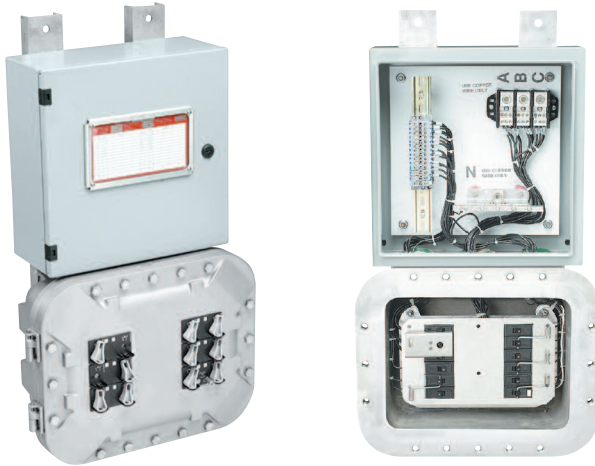

**Class I, Div. 2, Groups B,C,D**  
**Class I, Zone 2, Groups IIB+H<sub>2</sub>, IIA**  
**Class II, Div. 2, Groups F,G**  
**Class III, Div. 1 & 2**  
**NEMA, CSA Type 3, 4 (4X Optional)**



Classified — File E83969



Certified — File LR11713

**FEATURES-SPECIFICATIONS**

Catalog Numbers on this page are for the basic Termination Enclosure with distribution, neutral, ground bar and terminal blocks plus a Breaker Enclosure with internal pan. Enclosures are connected together with factory poured sealing chambers and mounted on aluminum frame for wall mounting. External breaker handles and internal branch breakers are not included and must be ordered as separate items for factory installation. (See page DE19)

<b>D2L PANELBOARDS WITHOUT MAIN BREAKER (MAIN LUGS ONLY) LESS BRANCH BREAKERS</b>					
<b>ELECTRICAL RATING</b>	<b>NUMBER OF BRANCH POLES</b>	<b>MAIN LUG RATING AMPS</b>	<b>CATALOG NUMBER BASIC ENCLOSURES</b>	<b>MAIN WIRE RANGE</b>	<b>PANEL SIZE</b>
Single Phase	12	100	<b>D2L-112-ML100</b>	M	A
3 Wire with Solid Neutral 120/240 VAC	24	225	<b>D2L-124-ML225</b>	N	B
	36	225	<b>D2L-136-ML225</b>	N	C
120/240 VAC	42	225	<b>D2L-142-ML225</b>	P	D
	12	100	<b>D2L-312-ML100</b>	M	A
Three Phase 4 Wire with Solid Neutral 120/208 VAC	24	225	<b>D2L-324-ML225</b>	N	B
	36	225	<b>D2L-336-ML225</b>	N	C
120/208 VAC	42	225	<b>D2L-342-ML225</b>	P	D

<b>D2L CIRCUIT BREAKER RATINGS CUTLER-HAMMER TYPE QC CIRCUIT BREAKERS</b>			
<b>TYPE</b>	<b>POLES</b>	<b>VOLTS</b>	<b>AMPERES SYMMETRICAL</b>
QC	1	120	10,000 AIC
	2	120/240	
	3	240	
QCSWN	1	120/240	10,000 AIC
	2	120/240	
QCFG	1	120	10,000 AIC
	2	120/240	
QCGFEP	1	120	10,000 AIC
	2	120/240	

<b>D2L PANELBOARDS WITH MAIN BREAKER LESS BRANCH BREAKERS</b>						
<b>ELECTRICAL RATING</b>	<b>NUMBER OF BRANCH POLES</b>	<b>MAIN BREAKER</b>		<b>CATALOG NUMBER BASIC ENCLOSURES</b>	<b>MAIN WIRE RANGE</b>	<b>PANEL SIZE</b>
		<b>AMPS</b>	<b>FRAME</b>			
Single Phase 3 Wire with Solid Neutral 120/240 VAC	10	100	QC	<b>D2L-110-MBQ100</b>	M	A
	22	100	QC	<b>D2L-122-MBQ100</b>	N	B
120/240 VAC	34	100	QC	<b>D2L-134-MBQ100</b>	N	C
	42	225	ED	<b>D2L-142-MBED225</b>	N	D
Three Phase 4 Wire with Solid Neutral 120/208 VAC	9	100	QC	<b>D2L-309-MBQ100</b>	M	A
	21	100	QC	<b>D2L-321-MBQ100</b>	N	B
120/208 VAC	33	100	QC	<b>D2L-333-MBQ100</b>	N	C
	42	225	ED	<b>D2L-342-MBED225</b>	N	D

*NOTE: To substitute a lower amperage main breaker change last three digits of catalog number to desired amperage.*

*Example: For a 50 amp main breaker part number = D2L-309-MBQ050*

*See page DE19 for Branch Breaker Selection*

*See page DE20 for Dimensions, Wire Range Chart and Wiring Diagrams.*

*Panels are constructed with Terminal Box on Top for Top Feed.*

*If Bottom Feed is required order modification D2MLBTM for inverted panel with Terminal Box on Bottom.*

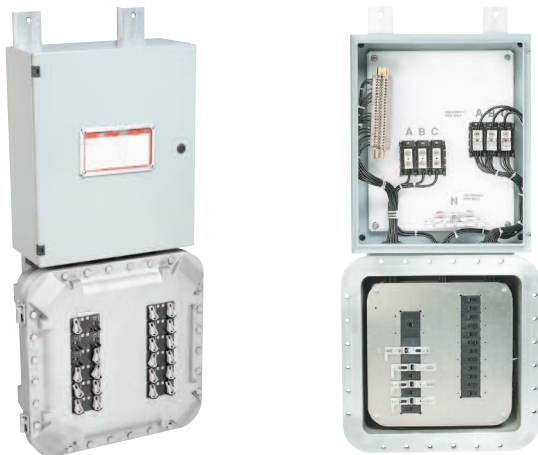

Class I, Div. 2, Groups B,C,D  
Class I, Zone 2, Groups IIB+H<sub>2</sub>, IIA  
Class II, Div. 2, Groups F,G  
Class III, Div. 1 & 2  
NEMA, CSA Type 3, 4 (4X Optional)



Classified — File E83969



Certified — File LR11713

### FEATURES-SPECIFICATIONS

Catalog Numbers on this page are for the basic Termination Enclosure with distribution, neutral, ground bar and terminal blocks plus a Breaker Enclosure with internal pan. Enclosures are connected together with factory poured sealing chambers and mounted on aluminum frame for wall mounting.

External breaker handles and internal branch breakers are not included and must be ordered as separate items for factory installation. (See page DE19)

CUTLER-HAMMER CIRCUIT BREAKER RATINGS FOR D2PC PANEL									
TYPE	NUMBER OF POLES	MAXIMUM VOLTS		AMPERES SYMMETRICAL					
		AC	DC	277 VAC	347 VAC	277/480 VAC	347/600 VAC	125 VDC	250 VDC
GHC	1	277	125	14,000		—	—	14,000	—
	2 & 3	277/480Y	250	14,000		14,000	—	—	14,000
GCH	1	347	125	—	10,000	—	—	14,000	—
	2 & 3	347/600Y	250	—	—	—	10,000	—	14,000

NOTE: GCH Breakers are CSA only.

PANELBOARDS WITHOUT MAIN BREAKER (MAIN LUGS ONLY) LESS BRANCH BREAKERS					
ELECTRICAL RATING	NUMBER OF BRANCH POLES	MAIN LUG RATING AMPS	CATALOG NUMBER BASIC ENCLOSURES	MAIN WIRE RANGE	PANEL SIZE
Three Phase	12	100	D2PC-312-ML100	M	E
4 Wire with Solid Neutral up to 480Y/277 VAC 600Y/347 VAC	24	225	D2PC-324-ML225	N	F
	36	225	D2PC-336-ML225	N	G
	42	225	D2PC-342-ML225	P	H

PANELBOARDS WITH MAIN BREAKER LESS BRANCH BREAKERS							
ELECTRICAL RATING	NUMBER OF BRANCH POLES	MAIN BREAKER			CATALOG NUMBER BASIC ENCLOSURES	MAIN WIRE RANGE	PANEL SIZE
		MAX VOLTS	AMPS	FRAME			
Three Phase 4 Wire with Solid Neutral 480Y/277 VAC 600Y/347 VAC	9	480Y/277	100	GHC	D2PC-309-MBGH100	M	E
	9	600Y/347	100	GCH	D2PC-309-MBGC100	M	E
	21	480Y/277	100	GHC	D2PC-321-MBGH100	N	F
	21	600Y/347	100	GCH	D2PC-321-MBGC100	N	F
	33	480Y/277	100	GHC	D2PC-333-MBGH100	N	G
	33	600Y/347	100	GCH	D2PC-333-MBGC100	N	G
	42	600Y/347	250	JDB	D2PC-342-MBJ250	N	H

Note special wiring conditions: GHC 480Y/277 circuit breakers are not suitable for 3 phase Delta (480)  
GCH 600Y/347 circuit breakers are not suitable for 3 phase Delta (600)  
GCH Rating is for CSA only not UL.

NOTE: To substitute a lower amperage main breaker change last three digits of catalog number to desired amperage.

Example: For a 50 amp main breaker part number = D2PC-309-MBGH050

See page DE19 for Branch Breaker Selection

See page DE20 for Dimensions, Wire Range Chart and Wiring Diagrams.

Panels are constructed with Terminal Box on Top for Top Feed.

If Bottom Feed is required order modification D2MLBTM for inverted panel with Terminal Box on Bottom.



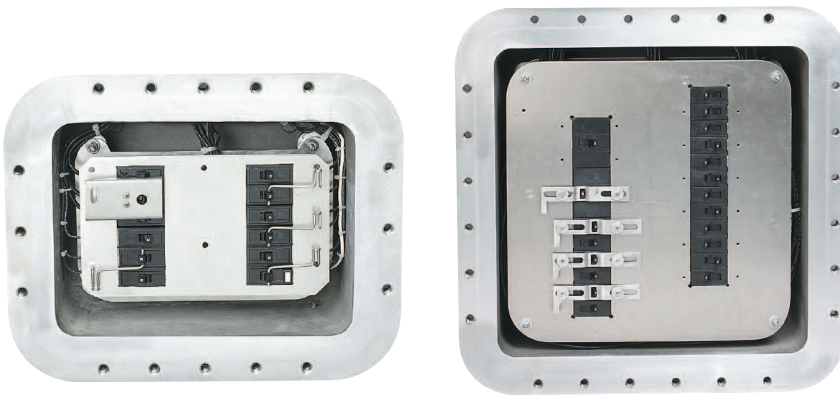

**Class I, Div. 2, Groups B,C,D**  
**Class I, Zone 2, Groups IIB+H<sub>2</sub>, IIA**  
**Class II, Div. 2, Groups F,G**  
**Class III, Div. 1 & 2**  
**NEMA, CSA Type 3, 4 (4X Optional)**



Classified — File E83969



Certified — File LR11713

**FEATURES-SPECIFICATIONS**

BRANCH CIRCUIT BREAKER SELECTION FOR D2L & D2PC FACTORY SEALED PANELBOARDS							
NUMBER OF POLES PER BREAKER	TRIP AMP RATING	CATALOG NUMBER					
		D2L SERIES LIGHTING PANEL				D2PC SERIES POWER PANEL	
		QC FRAME STANDARD	QC FRAME SWITCHED NEUTRAL	QCFG GROUND FAULT 5 MA	QCGFEP EQUIPMENT PROTECTION 30 MA	GHC FRAME 277/480Y VAC MAX	GCH FRAME 347/600Y VAC MAX
(1) Single Pole	Space	D2BLA1000	—	D2BLC1000	D2BLE1000	D2BGHC1000	D2BGCH1000
	15	D2BLA1015	—	D2BLC1015	D2BLE1015	D2BGHC1015	D2BGCH1015
	20	D2BLA1020	—	D2BLC1020	D2BLE1020	D2BGHC1020	D2BGCH1020
	30	D2BLA1030	—	D2BLC1030	D2BLE1030	D2BGHC1030	D2BGCH1030
	40	D2BLA1040	—	D2BLC1040	D2BLE1040	D2BGHC1040	D2BGCH1040
	50	D2BLA1050	—	—	D2BLE1050	D2BGHC1050	D2BGCH1050
	60	D2BLA1060	—	—	—	D2BGHC1060	D2BGCH1060
	70	D2BLA1070	—	—	—	D2BGHC1070	D2BGCH1070
	90	D2BLA1090	—	—	—	D2BGHC1090	D2BGCH1090
	100	D2BLA1100	—	—	—	D2BGHC1100	D2BGCH1100
(2) Double Pole	Space	D2BLA2000	D2BLF2000	D2BLC2000	D2BLE2000	D2BGHC2000	D2BGCH2000
	15	D2BLA2015	D2BLF2015	D2BLC2015	D2BLE2015	D2BGHC2015	D2BGCH2015
	20	D2BLA2020	D2BLF2020	D2BLC2020	D2BLE2020	D2BGHC2020	D2BGCH2020
	30	D2BLA2030	D2BLF2030	D2BLC2030	D2BLE2030	D2BGHC2030	D2BGCH2030
	40	D2BLA2040	—	D2BLC2040	D2BLE2040	D2BGHC2040	D2BGCH2040
	50	D2BLA2050	—	D2BLC2050	D2BLE2050	D2BGHC2050	D2BGCH2050
	60	D2BLA2060	—	—	—	D2BGHC2060	D2BGCH2060
	70	D2BLA2070	—	—	—	D2BGHC2070	D2BGCH2070
	90	D2BLA2090	—	—	—	D2BGHC2090	D2BGCH2080
	100	D2BLA2100	—	—	—	D2BGHC2100	D2BGCH2100
(3) Three Pole	Space	D2BLA3000	D2BLF3000	—	—	D2BGHC3000	D2BGCH3000
	15	D2BLA3015	D2BLF3015	—	—	D2BGHC3015	D2BGCH3015
	20	D2BLA3020	D2BLF3020	—	—	D2BGHC3020	D2BGCH3020
	30	D2BLA3030	D2BLF3030	—	—	D2BGHC3030	D2BGCH3030
	40	D2BLA3040	—	—	—	D2BGHC3040	D2BGCH3040
	50	D2BLA3050	—	—	—	D2BGHC3050	D2BGCH3050
	60	D2BLA3060	—	—	—	D2BGHC3060	D2BGCH3060
	70	D2BLA3070	—	—	—	D2BGHC3070	D2BGCH3070
	90	D2BLA3090	—	—	—	D2BGHC3090	D2BGCH3090
	100	D2BLA3100	—	—	—	D2BGHC3100	D2BGCH3100

NOTES: 1) Above part numbers include external handle, trip mechanism, locking tab and internal branch circuit breaker.

2) Refer to page DE16 for complete ordering information and examples.

3) Refer to pages DE17 and DE18 for maximum voltage and ratings of circuit breakers.

4) Space = External handle, trip mechanism installed to allow for future installations of breakers.

5) Ground Fault and Equipment protection breakers include external button for test purpose.



**KILLARK®**



Class I, Div. 2, Groups B,C,D  
Class I, Zone 2, Groups IIB+H<sub>2</sub>, IIA  
Class II, Div. 2, Groups F,G  
Class III, Div. 1 & 2  
NEMA, CSA Type 3, 4 (4X Optional)



Classified — File E83969



Certified — File LR11713

### FEATURES-SPECIFICATIONS

WIRE RANGE CHART	
REFERENCE LETTER	MAIN WIRE RANGE
M	2/0-#14AWG
N	350MCM-#6AWG
P	400MCM-#6AWG

Standard Panelboard Wiring Diagram

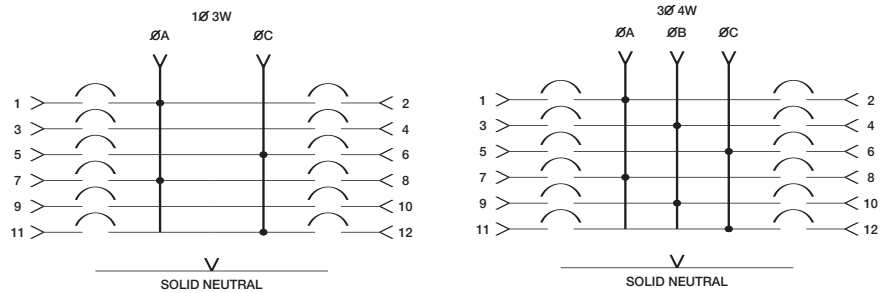

DIMENSIONS FOR PANELS WITH STANDARD STEEL PAINTED TERMINAL ENCLOSURES											
PANEL SIZE	MAXIMUM CIRCUITS	A	B	C	D	E	F	G	H	J	L
A	12	16"	20-1/8"	11"	8-7/16"	33-27/32"	31-1/2"	16"	15-1/4"	8-15/16"	35-3/8"
B	24	20"	21-1/4"	11-7/32"	10-7/16"	46-31/32"	44-5/8"	24"	20-3/8"	10-15/16"	48-1/2"
C	36	20"	22-1/8"	14-1/16"	10-7/16"	55-27/32"	53-1/2"	24"	29-1/4"	11-3/8"	57-3/8"
D	42	24"	23-3/16"	14-3/8"	10-7/16"	67"	64-5/8"	24"	40-3/8"	13-1/4"	68-17/32"
E	12	16"	23-1/4"	11-21/32"	8-7/16"	35"	32-5/8"	16"	16-3/8"	12-7/8"	36-1/2"
F	24	20"	24-1/8"	12-1/16"	10-7/16"	49-27/32"	47-1/2"	24"	23-1/4"	13-3/8"	51-3/8"
G	36	20"	23-3/16"	13-25/32"	10-7/16"	54-31/32"	52-5/8"	24"	28-3/8"	13"	56-1/2"
H	42	24"	23-3/16"	14-3/8"	10-7/16"	67"	64-5/8"	24"	40-3/8"	13-1/4"	68-17/32"

DIMENSION CHANGE FOR PANELS WITH ALTERNATE TERMINAL ENCLOSURES				
PANEL SIZE	D2 STAINLESS STEEL OPTION		D2 FIBERGLASS OPTION	
	A	G	A	G
A	20	16	24	14
B	20	24	24	24
C	20	24	24	24
D	24	24	24	24
E	20	16	24	14
F	20	24	24	24
G	20	24	24	24
H	24	24	24	24

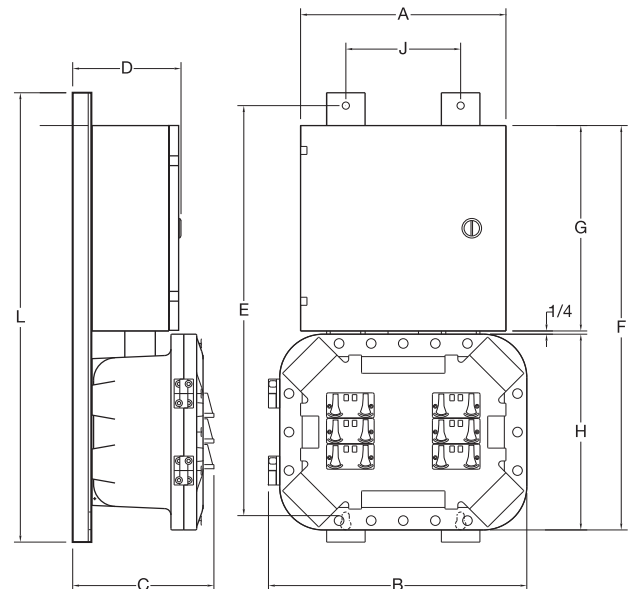

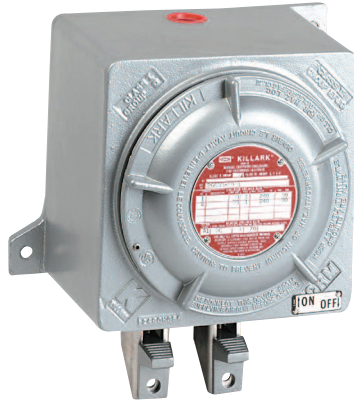

**Class I, Div. 1 & 2, Groups B,C,D**  
**Class I, Zones 1 & 2, Groups IIB+H<sub>2</sub>, IIA**  
**Class II, Div. 1 & 2, Groups E,F,G**  
**Class III**  
**NEMA 3R, 7(B,C,D) 9(E,F,G)**

Listed - File E83969

See files for details or call Killark.

**Applications**

- Indoor or outdoor hazardous areas where flammable gases or vapors, combustible dusts, or easily ignitable fibers or flyings may be present
- Provides overcurrent and short circuit protection of branch lighting, heating and appliance circuits

**Features**

- Compact rectangular enclosure with threaded cover allows easy access
- GCBB/2GCBB provided with two 3/4" - 14 NPT drilled and tapped conduit openings, one top and one bottom
- 3GCBB provided with three 3/4" - 14 NPT drilled and tapped conduit openings, one top and two bottom
- 4GCBB provided with four 3/4" - 14 NPT drilled and tapped conduit openings, two top and two bottom
- Cutler-Hammer Type QC Quicklag Circuit Breakers (These Assemblies include the Breakers as indicated)
- Push pull handle mechanism operates circuit breakers
- Handle mechanism supplied as standard with "Lockout" in off position
- Enclosures are made from copper-free cast aluminum alloy (less than 4/10 of 1%)
- Special combinations of breaker amperage are available, consult factory for details

**FEATURES-SPECIFICATIONS**

GCBB 15/40A TRIP QUICKLAG				
CATALOG NUMBER				TRIP AMPS
ONE 1-POLE 120 VOLTS AC	ONE 2-POLE 120/240 VOLTS AC	ONE 3-POLE 240 VOLTS AC	TWO 1-POLE 120/240 VOLTS AC	
GCBB-15Q1	GCBB-15Q2	GCBB-15Q3	2GCBB-15Q1	15
GCBB-20Q1	GCBB-20Q2	GCBB-20Q3	2GCBB-20Q1	20
GCBB-30Q1	GCBB-30Q2	GCBB-30Q3	2GCBB-30Q1	30
GCBB-40Q1	GCBB-40Q2	GCBB-40Q3	2GCBB-40Q1	40
GCBB-1Q	GCBB-2Q	GCBB-2Q	2GCBB-1Q	Enclosure only

GCBB 15/40A TRIP QUICKLAG				
CATALOG NUMBER				TRIP AMPS
THREE 1-POLE 120 VOLTS AC	FOUR 1-POLE <sup>Ⓢ</sup> 120 VOLTS AC	TWO 2-POLE <sup>Ⓢ</sup> 120/240 VOLTS AC	ONE 1-POLE <sup>Ⓢ</sup> ONE 3-POLE 120/240 VOLTS AC	
3GCBB-15Q1	4GCBB-15Q1	2GCBB-15Q2	2GCBB-15Q13	15
3GCBB-20Q1	4GCBB-20Q1	2GCBB-20Q2	2GCBB-20Q13	20
3GCBB-30Q1	4GCBB-30Q1	2GCBB-30Q2	2GCBB-30Q13	30
3GCBB-40Q1	4GCBB-40Q1	2GCBB-40Q2	2GCBB-40Q13	40
3GCBB-1Q	4GCBB-1Q	2GCBB-2Q	2GCBB-13Q	Enclosure only

<sup>Ⓢ</sup>SU17 100 Amp Solid Neutral will not fit in this assembly.

MODIFICATIONS	
SUFFIX NUMBER	DESCRIPTION
SU3	Drain and breather
KIT-251	150 amp ground lug
KIT-252	250 amp ground lug
SU17	Solid neutral

INTERRUPTING RATINGS			
FRAME SIZE	VOLTAGE	AMPS ASYMMETRICAL	AMPS SYMMETRICAL
QC	120/240 VAC	10,000	10,000
QC	240 VAC	10,000	10,000
QC	24/48 DC	5,000	5,000
QC	62/80 DC	3,800	3,800

**Dimensions**

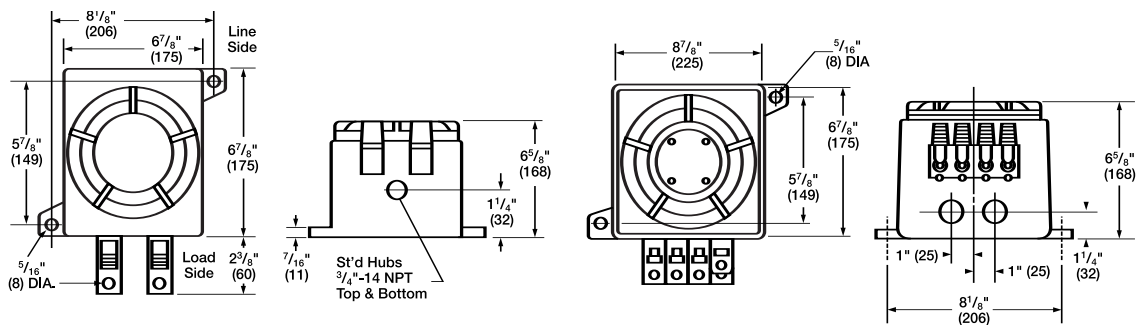

**KILLARK**

**GCBB/2GCBB**

**3GCBB/4GCBB**



Class I, Div. 1 & 2, Groups B,C,D  
 Class I, Zones 1 & 2, Groups IIB+H<sub>2</sub>, IIA  
 Class II, Div. 1 & 2, Groups E,F,G  
 Class III, Div. 1 & 2  
 NEMA 3, 7(B,C,D) 9(E,F,G)

 Listed - File E83969

 Certified - File LR061895-2

## FEATURES-SPECIFICATIONS

### Applications

GFCS Series of Ground Fault Control Stations are used for the additional safety of personnel, and for equipment protection in remote areas.

### Features

- Factory Sealed Ground Fault Chamber. (Assemblies in Group B areas must be sealed within 6" of enclosure. Other area classifications do not require the use of seals)
- 1" NPT top and bottom conduit openings
- External Push-to-Test Button and Pilot Light for monitoring
- On-Off-Trip-Reset External Handle can be locked in On-Off positions
- 5ma Ground Fault Circuit Breaker for People Protection. 30ma Ground Fault circuit Breaker for Equipment Protection and heat tracing circuits
- Electrical Rating-120 VAC (single pole) 120/240 VAC (two pole) (10,000 AIC)

### Material/Finish

- Enclosure: Copper-free cast aluminum (less than 4/10 of 1%)
- External Hardware: Stainless Steel
- Standard Finish: Electrostatically applied gray powder epoxy polyester finish

GFCS GROUND FAULT CONTROL STATION			
CATALOG NUMBER	NUMBER OF POLES	MILLIAMP TRIP	BREAKER AMPERAGE
GFCS05151	1	5	15
GFCS05201	1	5	20
GFCS05301	1	5	30
GFCS30151	1	30	15
GFCS30201	1	30	20
GFCS30301	1	30	30
GFCS05152	2	5	15
GFCS05202	2	5	20
GFCS05302	2	5	30
GFCS30152	2	30	15
GFCS30202	2	30	20
GFCS30302	2	30	30

### Dimensions

